

INSTALLATION, OPERATION and MAINTENANCE INSTRUCTIONS for SURFACE MOUNTED WARM AIR CEILING HEATERS

Catalogue Numbers: HE7247 & HE7267 (230/240V)
 HE7248 (220V)

RETAIN THIS LEAFLET FOR FUTURE MAINTENANCE

ELECTRICAL CONNECTIONS

Mains power is fed into the remote switch control. The remote switch control is then connected to the appliance via the Terminal Box. The switch splits the power feed to the appliance allowing 'fan only - cold blow' or 'fan plus heater - hot blow' operation.

Note: AT ALL TIMES THE APPLIANCE AND REMOTE CONTROL SWITCH MUST BE EARTHED.

- 1 Feed mains power 'L' and 'N' to input side of Left Hand switch.
- 2 Connect output side of Left Hand switch 'L' to Terminal Box connection 'H'.
 Connect output side of Left Hand switch 'N' to Terminal Box connection 'F' making sure this switch output is still cross linked to the input side of the Right Hand switch.
- 3 Connect output side of Right Hand switch to Terminal Box connection 'N'.

OPERATION

Remote Control Switch



- 1 Left 'OFF' / Right 'OFF'
 Appliance 'OFF'
- 2 Left 'ON' / Right 'OFF'
 Fan only - Cold blow
- 3 Left 'ON' / Right 'ON'
 Fan plus heater - Hot blow
- 4 Left 'OFF' / Right 'ON'
 Appliance 'OFF'

This Claudgen Ceiling Heater is designed for suspension from a ceiling using threaded bar. It is supplied with stud bar mounting kit, painted enclosure and remote mounting control box.

ELECTRICAL CONNECTIONS

The HE7247 has a heating load of 4.5kW - 230/240V 50Hz
 The HE7267 has a heating load of 6.0kW - 230/240V 50Hz
 The HE7248 has a heating load of 4.5kW - 220V 50Hz

The connections to be made between the heater and the remote control box are shown in Fig. 3. An earth terminal is adjacent to the terminal block and is clearly marked with the symbol ⚡

The unit must be wired in accordance with I.E.E regulations for the Electrical Equipment of Buildings and the installer should ensure that a suitable isolating switch is connected in the mains supply.

Fig. 2 shows wiring diagram.

CONTROL

The remote control box houses 2 double pole 20 amp rocker switches and gives the following functions:

SWITCH 1 (LH)	OFF/FAN ONLY
SWITCH 2	FULL HEAT

MOUNTING

The fan heater box can only be fitted one way round (see Fig.1), as 2 of the studs are offset. This ensures that the fan outlet lines up with the discharge grille and also that the wiring is always sited the same side.

The diffuser is attached to the discharge grille with 4 small clips, which can be removed if necessary.

The discharge grille has 4 additional studs, plus nuts/washer, to enable the unit to be chain mounted, if required.

There are also extra holes in the box to enable the unit to be suspended via wires.

MAINTENANCE

ALWAYS ENSURE THAT THE MAIN EXTERNAL ELECTRICITY SUPPLY IS SWITCHED OFF BEFORE SERVICING THIS HEATER.

To obtain the best results from the heater, it is essential to avoid the accumulation of dust and dirt within the unit on the air inlet and discharge grilles. Regular cleaning is necessary with particular attention to the removal of any dirt on the fan rotor blades. Cleaning of the fan is best carried out with a soft brush.

PROTECTION (Thermal Cut Out)

The unit is protected in the event of fan failure, or an obstruction of the free airflow, by a thermal PTC Self Hold Cut Out. Having tripped the PTC Cut Out remains open, effectively switching off the heating elements, as long as mains power is available inside the appliance. The PTC Cut Out will only reset when the appliance is switched OFF and allowed to cool for at least 20 minutes.

To reset the PTC Self Hold Cut Out

DO NOT ADJUST BY HAND ANY INTERNAL COMPONENTS

- a) The cutout is reset by switching OFF mains power to the appliance.
- b) Allow the appliance to cool for 20 minutes
 Re-start, switch ON the appliance. If the cutout trips again, a qualified electrician should be consulted.

TO REPLACE A FAN/HEATER ASSEMBLY

- a) Switch off the mains supply
- b) Release the six nuts and washers fixing the fan heater box to the discharge grille
- c) Disconnect the fan heater wiring from the mains terminal block and earth stud
- d) Remove the fan heater from the box (four screws)
- e) Fit the replacement unit and re-assemble in the reverse order.

TO REPLACE A SWITCH IN THE CONTROL BOX

- a) Switch off the mains supply
- b) Remove the switch box cover
- c) Disconnect the wiring to the switch
- d) Release the spring clips and push out the switch
- e) Fit the replacement switch, reconnect the wiring and replace the cover

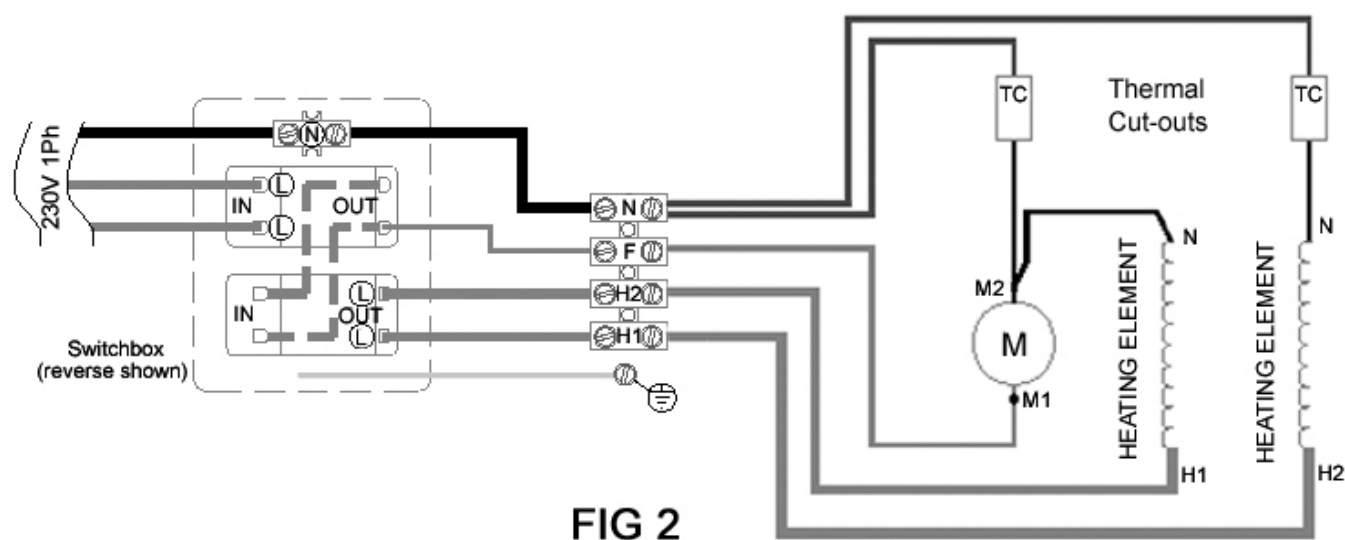
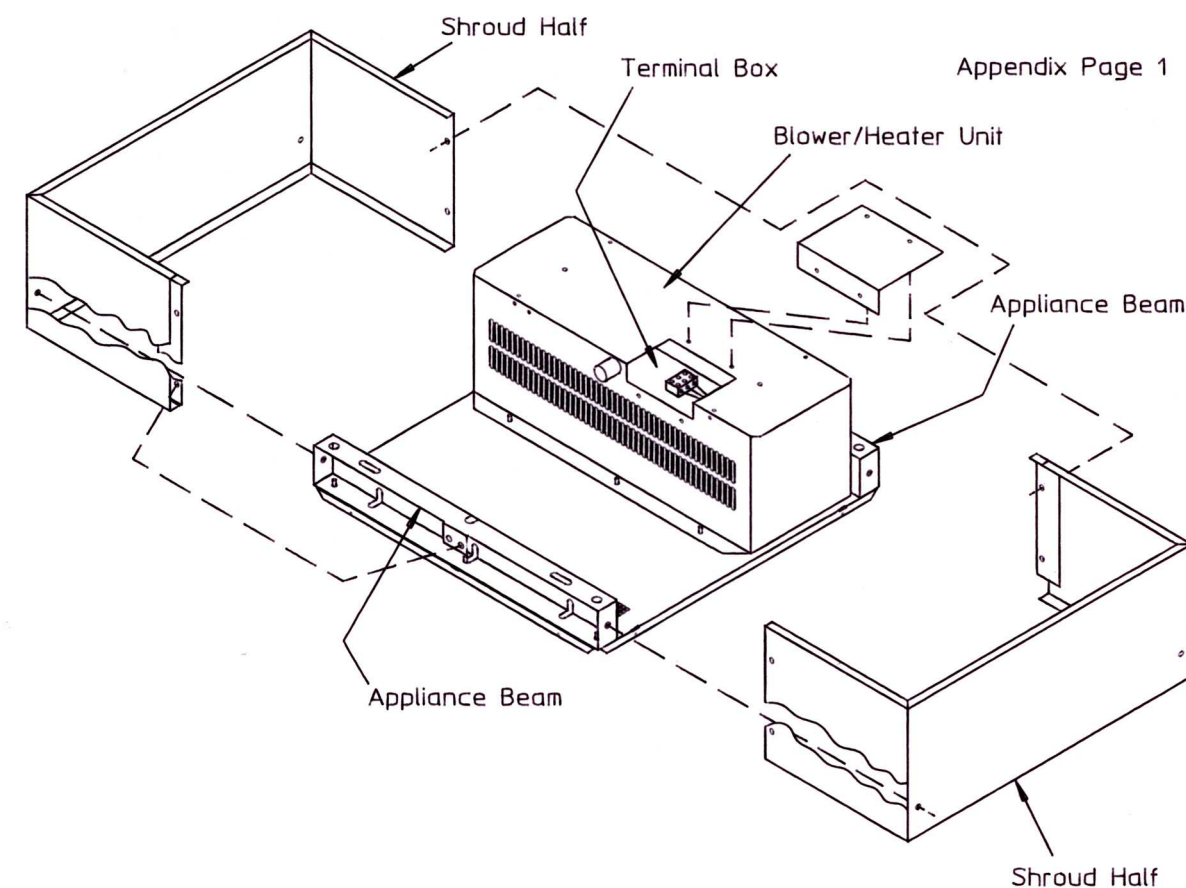
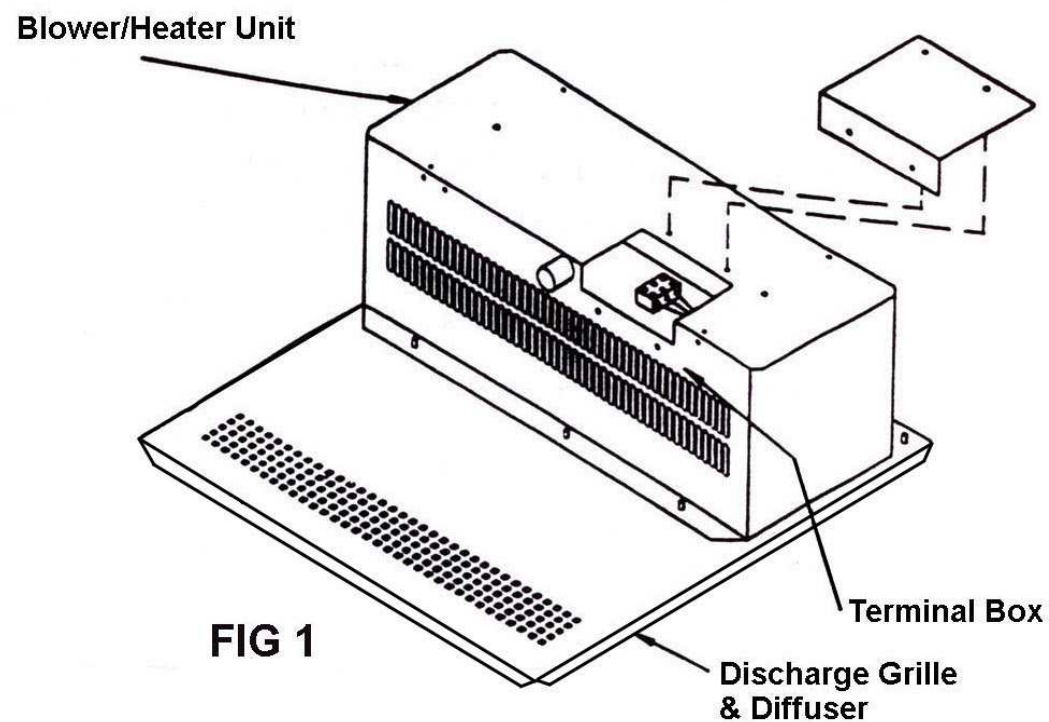

INSTALLATION/HANGING

Note: The appliance weighs 17.5 kg

Note: Optimum height above floor: 3.0 to 3.5 metres

1 Split and remove shroud

A pair of machine screws hold each shroud half together at each joint. A machine screw secures each shroud half to each appliance beam. Remove these machine screws and slide each shroud half off the appliance base panel.

Note: The base panel fits inside the shroud halves. The diffuser is already clipped into and under the base panel and need not be removed.

2 Hanging Rod Positions

With the shroud removed the two appliance beams reveal the holes/slots shown and dimensioned below. It is required that two $\varnothing 10$ mm hanging rods (stud bars) support each appliance beam. The rods pass through and into each appliance beam. Support washers together with nuts locate and lock the appliance beams after adjustment to level the appliance.

3 Replace Shroud Halves

The reverse of '1' above. Slide shrouds beneath and around base panel. Secure each shroud half to each appliance beam with machine screws. Screw shroud halves together at each joint.

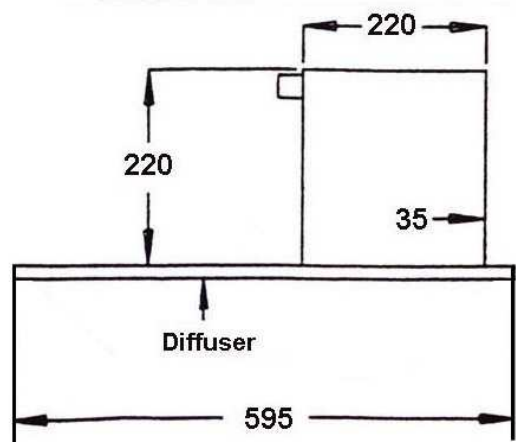

Shown without shrouds for clarity

FIG 4