

MAINTENANCE

ALWAYS ENSURE THAT THE MAIN EXTERNAL ELECTRICAL SUPPLY IS SWITCHED OFF BEFORE ANY MAINTENANCE IS CARRIED OUT.

To obtain the best results from the heater, it is necessary to avoid any accumulation of dust or dirt within the unit or on the air inlet grille. The unit should be cleaned regularly.

SAFETY

This equipment has been designed and manufactured to the highest international standards but, like all electrical appliances which are operated by mains voltage, care must be taken if you are to obtain the best results and safety is to be assured.

NOTE: The appliance is not intended for use by persons (including children) with reduced physical, sensory or mental capabilities, or lack of experience and knowledge unless they have been given supervision or instruction concerning use of the appliance by a person responsible for their safety.

Children should be supervised to ensure that they do not play with the appliance.

- Do NOT use this appliance in bathrooms or where similar conditions of excessive moisture are present.
- No NOT handle the appliance with wet hands.
- Do NOT use the appliance in an enclosed room so small that the heater will generate ambient temperatures in excess of 30°C.
- Do NOT use the appliance with young children unattended.
- Do NOT use the appliance in rooms where excessive dust is generated or present.
- Do NOT touch THE outlet grille when appliance is in use.
- Do NOT cover or restrict any aperture of the appliance when in use.
- Do NOT use the appliance if damaged.

If the appliance has been kept in freezing conditions, run at cold/fan setting for 5 minutes before using heat settings.

This appliance meets the requirements of EU Directive 98/336/EEC for EMC.

GUARANTEE

This guarantee is offered to you as an extra benefit and does not affect your legal rights.

All electrical appliances produced for the Company are guaranteed for one year against faulty material or workmanship. This applies only if the appliance has been used for purposes in accordance with the instructions provided and has not been connected to an unsuitable electricity supply, or subject to misuse, neglect, damage or modified or repaired by any person not authorised by us.

The correct electricity supply voltage is shown on the rating label attached to the appliance.

Please retain your receipt as proof of purchase.

CUSTOMER HELPLINE

Should you need any advice on the use of your new Consort product, or should you require service or repair, please contact our Helpline:

☎ 01646 692172 Mon to Fri 8.30 am to 3.30 pm

Consort Equipment Products Limited

Thornton Industrial Estate, Milford Haven, Pembrokeshire, SA73 2RT

Fax: 01646 69519 Email: enquiries@consortepl.com Web: www.consortepl.com

CONSORT

Quality Space Heaters

INSTALLATION, OPERATION AND MAINTENANCE INSTRUCTIONS FOR

CHELSEA WALL MOUNTED FAN HEATER

FOR WIRELESS ELECTRONIC CONTROLS

Catalogue Numbers: WMHW3 (brushed aluminium fascia)



PLEASE RETAIN THIS LEAFLET FOR FUTURE MAINTENANCE

INSTALLATION

Ensure the electricity supply is disconnected from any relevant fixed wiring before commencing the installation. The supply circuit must be adequate for the input of the appliance and must be protected by a 13 Amp fuse.

The heater must not be located immediately below a fixed socket outlet.

CONNECTION TO THE MAIN SUPPLY

Electrical installation should be carried out by a competent installer, preferably registered with NICEIC (National Inspection Council for Electrical Installation Contracting) in accordance with the 16 edition of the IEE Wiring Regulations, (BS.7671: 1992), and any relevant Local Authority Bye-Laws.

This heater is fitted with a 3-core mains supply cable and should be permanently connected to the electricity supply via a double pole switch having 3mm gap on each pole.

A switched fused connection unit to BS.1363 Part 4 is a recommended mains supply connection accessory to ensure compliance with safety requirements applicable to a fixed-wiring installation.

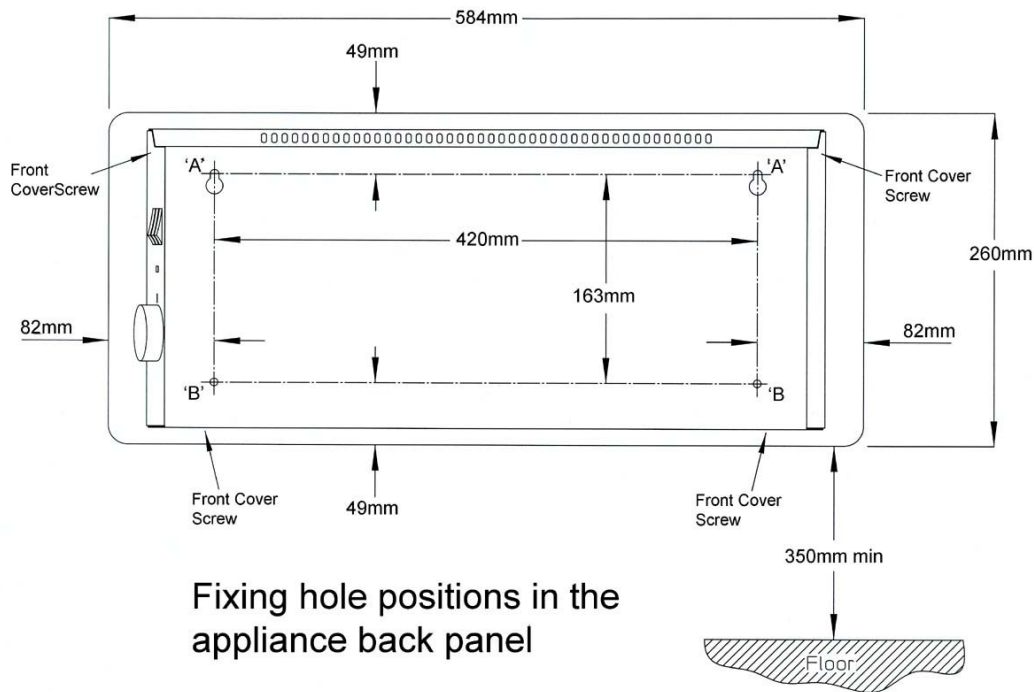

PROCEDURE

1. Remove the front cover (2 screws on the side and 2 screws on the bottom).
2. Mark screw fixing positions on the wall in accordance with dimensions shown in the diagram. The unit must be screwed to the wall with 4 screws through the holes provided in the back panel. Drill 4 holes in the wall to suit No.10 wood screws (round head) and insert wall plugs. At screw position 'A', screws can now be screwed in until the heads are approximately 5 mm from the wall. The unit can be hung on these 2 screws, whilst the lower placed screws 'B' are positioned. Before finally tightening all 4 screws ensure the unit is horizontal.
3. Refit front cover. Ensure grille bars internal/external are spaced equally.

OPERATION

This heater can only be used when connected to a CZC1 wireless programmable timer. Each CZC1 can control any number of heaters. The heater has an indicator light positioned behind the fascia panel on the top right side. The light may be:

- | | | |
|-------------------|---|---|
| Green | - | when no heat is needed |
| Yellow | - | when some heat is needed to maintain the room temperature |
| Red | - | when the heater is on full power |
| Fast Flashing Red | - | when the heater has overheated and the Electronic Safety Control has switched the heater off. |

Please refer to the CZC1 user and operating instructions for full operational details.

ELECTRONIC SAFETY CONTROL

The appliance is fitted with an Electronic Safety Control (ES). This is a safety device, which switches the heater off if, for any reason, the appliance overheats. Overheating is indicated by a fast flashing red light. The ES control can only be re-set after the appliance has cooled down. In order to re-set the ES control, proceed as follows:

- Switch the appliance off at the mains by using the isolator switch and leave to cool down for approximately 5 minutes.
- Switch appliance back on and the ES control will re-set.
- Ensure that the appliance is functioning correctly. If the ES control operates again, the appliance should be checked by a competent electrician.