

INSTALLATION, OPERATION AND MAINTENANCE INSTRUCTIONS FOR

Heat-Zone Fan Heater

Catalogue Numbers: HE7010 3 kW 230/240 V HE7020 4.5 kW 230/240 V
HE7030 3 kW 220 V HE7040 4.5 kW 220 V

PLEASE RETAIN THIS LEAFLET FOR FUTURE MAINTENANCE

MODEL

Heat-Zone is a quiet Fan Heater designed for Commercial and Industrial situations, and is suitable for mounting on the wall. The Heat-Zone incorporates a tangential flow fan and the unit is designed to operate in free air conditions. It is important that there should be no restriction on the free flow of air through the unit.

PROTECTION

The unit is protected in the event of fan failure, or an obstruction of the free airflow, by a single thermal PTC Self Hold Cut-out. Having tripped the PTC Cut-out remains open, effectively switching off the heating elements, as long as mains power is available inside the appliance. The PTC Cut-out will only reset when the appliance is switched OFF and allowed to cool for at least 20 minutes.

MOUNTING

The normal mounting height is 2.3m above the floor, although this will depend to some extent on the situation. The unit should be mounted at least 450mm below ceiling.

The heater can be arranged to blow air at any angle, from horizontal to vertically downwards, subject to the conditions mentioned below. It is suggested that an angle of 45° is a convenient starting point when setting up the unit.

It must always be installed with the axis of the motor horizontal. Failure to ensure this will result in excessive bearing wear and premature failure.

A mounting bracket is provided for mounting to a wall.

The heater should not be mounted in situations where it may be subject to conditions of excessive humidity or the atmosphere is corrosive.

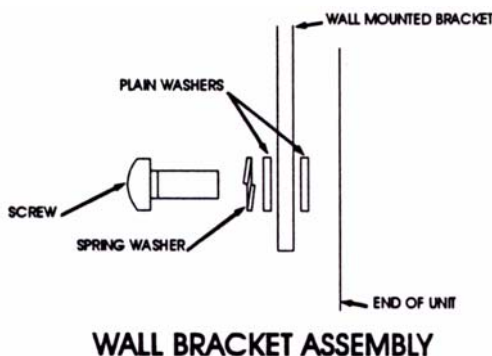

INSTALLATION

The normal mounting height is 2.3m above the floor, although this will depend to some extent on the situation. The unit should be mounted at least 450mm below ceiling. To the unit connect a suitable length of 3 or 4 core flexible cable (1.5 mm² for 3 kW or 2.5 mm² for 4.5 kW) to the input terminal block. (3 core for 'on/off' control, 4 core for 'fan only and fan heater', see Electrical Connection).

Loosen mounting screws, allowing the mounting bracket to be removed from the unit. Making sure that the mounting bracket is horizontal, fix the bracket to the wall using 3 x No 8 wood screws.

Place the unit on the mounting bracket ensuring the washers are spaced as on diagram (a plain washer either side of the mounting bracket).

Tighten screws to hold the unit at the required angle.

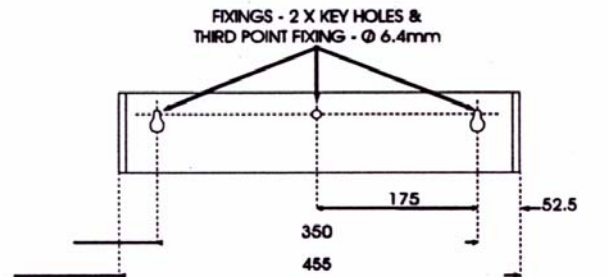

NOTE: THE MOUNTING BRACKET, ONCE REMOVED, MAY BE USED AS A TEMPLATE

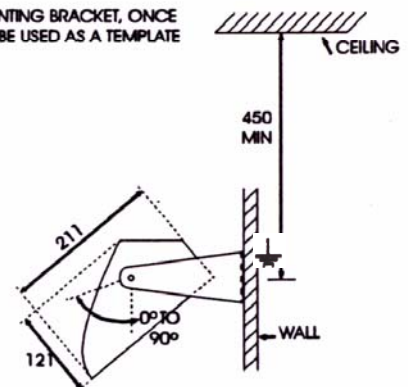

ELECTRICAL CONNECTIONS

These units are suitable for connection to a 230/240V 50Hz single phase ac supply (220 V for Models HE7030 & HE7040). The units consume 3kW (HE7010 & HE7030) or 4.5 kW (HE7020 & HE7040) of electrical power when the fan and heater are in operation.

To connect a supply to the heater, first remove the top cover by unscrewing the 4 fixing screws (2 either side), then lifting off the cover. The input terminal block, marked NFH, is fitted at the left hand side of the unit looking from above (at the opposite end to the fan motor). The earth terminal is on the case below the terminal block, marked with the earth symbol :

For safety reasons, a sound earth connection **MUST ALWAYS** be made to the unit before being put to use.

The Heat-Zone can be connected in a number of ways depending on the form of control required. Whichever method is used, a double-pole isolator switch should be included in the installation.

SIMPLE ON/OFF CONTROL

If it is desired to control the Fan and the Heat together, then connect the live supply wire to the terminal marked 'F', the neutral wire to the terminal marked 'N', and the earth wire to the earth terminal. The 'Link' is incorporated in the unit when it leaves the factory.

SEPARATE FAN AND HEAT CONTROL

If it is desired to control the Fan and the Heat separately, use the HE7001 Remote Control Unit which is available independently.

Remove the 'Link' between terminals 'F' and 'H'. Make connections from the mains to the switch, and from the switch to the heater, as indicated.

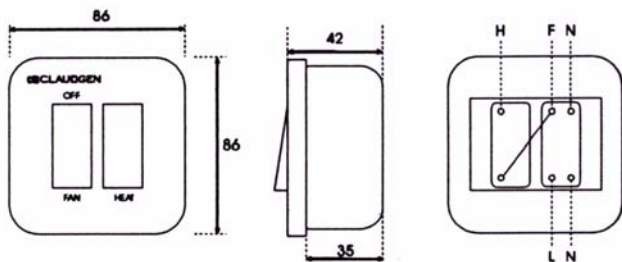

HE7001 Remote Control Unit comprising one Double Pole and one Single Pole 20 amp Rocker Grid Switches in a surface mounting metal box 86 mm x 86 mm x 42 mm deep. The cover plate is marked as indicated, and the interconnection between the switches is made to ensure that the heater cannot be connected without the fan in operation.

MAINTENANCE

ALWAYS ENSURE THAT THE MAIN EXTERNAL ELECTRICITY SUPPLY IS SWITCHED OFF BEFORE ATTENDING TO THE SERVICING OF THE UNIT.

To obtain the best results from Heat-Zone it is necessary to avoid any build-up of dust or dirt within the unit or on the air inlet grille. For this reason the unit should be cleaned regularly, paying particular attention to the removal of dirt build-up on the back of the fan rotor blades.

The removal of dust and dirt is best achieved using a soft brush.

THERMOSTAT CONTROL

The connections are the same as in Fig 3a below, except that the 'live' connection is taken through a room thermostat. This thermostat must be capable of switching 13 amps ac at 240 volts.

IN ALL CASES, THE UNIT SHOULD BE WIRED IN ACCORDANCE WITH IEE REGULATIONS FOR THE ELECTRICAL EQUIPMENT OF BUILDINGS.

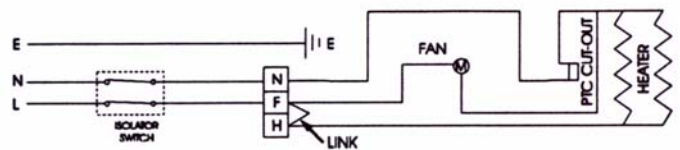

Fig. 3a

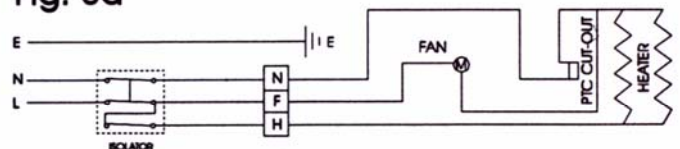

Fig. 3b

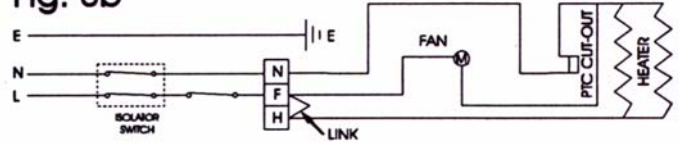

Fig. 3c

TO RESET THE PTC SELF-HOLD CUT-OUT

DO NOT ADJUST BY HAND ANY INTERNAL COMPONENTS

- The Cut-out is reset by switching OFF mains power to the appliance.
- Allow the appliance to cool for 20 minutes.
- Restart, switch ON the appliance. If the Cut-out trips again a qualified electrician should be consulted.

TO REMOVE THE FAN HEATER ASSEMBLY

- Remove the top cover as described under the heading 'Electrical Connection'.
- Disconnect the supply wires to the input terminal block and earth post.
- Unscrew the bush holding the terminal block assembly to the main case.
- Remove the 4 nuts and washers holding the fan heater assembly in place.
- The fan heater assembly, terminal block and internal wiring can now be removed.

The assembly is replaced by carrying out the above operations in the order e) to a).

SPARES

It is essential when ordering spares or replacement parts to state the model number and serial number on the rating plate fixed to the top of the unit.

In the interest of progress the Company reserve the right to vary specifications from time to time without notice. The material listed is offered subject to the Company's General Conditions of Sale, a copy of which may be obtained by request.